

T525 (R) specification

For Applications with engines up to 410 kW (550 hp) gross input power and up to 2241 N•m (1653 lb-ft) gross input torque.

RATINGS

Input Torque Gross N•m (lb-ft)	Input Power Gross ¹ Kw (hp)	Turbine Torque Net ² N•m (lb-ft)	GVW kg (lbs)	Vocations
Tour Coach 2241 (1653)	410 (550)	3322 (2450)	Unlimited	Tour Coach

1. Gross Power rating as defined by ISO 1585 or SAE J1995. 2. Turbine Torque limit based on ISCAAN standard deductions.

ENGINE INTERFACES

Acceptable full-load engine governed speed	1700 – 2300 rpm
Acceptable engine idle speed range (with transmission in Drive)	500 – 800 rpm

MOUNTING

To Engine	SAE No.1
In Chassis	Rear support available (required for some installations)

TORQUE CONVERTER

Type One stage, three element, polyphase. Includes standard integral damper which is operational in lockup.

Model	Stall Torque Ratio
TC-521	2.42
TC-531	2.34
TC-541	1.90
TC-551	1.79
TC-561	1.58

MECHANICAL RATIOS (Gear ratios do not include torque converter multiplication)

Range

First	3.51 : 1
Second	1.91 : 1
Third	1.43 : 1
Fourth	1.00 : 1
Fifth	0.74 : 1
Sixth	0.65 : 1
Reverse	-4.80 : 1

CONTROL SYSTEM

Description	Allison 4th Generation Electronic Controls with closed loop adaptive shifts
Shift Sequences	[C = Converter mode (lockup clutch disengaged); L = Lockup mode (lockup clutch engaged)] Tour Coach Standard: 1C-[1L]-2C-2L-3L-4L-5L Optional: 1C-[1L]-2C-2L-3L-4L-5L-6L

TCM must be calibrated for "1L" option. Second-gear-start calibrations are not available for all vehicle applications.

Driver-to-Transmission Interface	Cab-mounted shift selector, pushbutton or lever with two-digit display (range selected and range attained)
---	--

Communication Protocol - Engine/Vehicle Systems Interface	SAE J1939, SAE J1587, ISO 9141, IESCAN
--	--

PHYSICAL DESCRIPTION

	Installation length*	Dry weight	Depth, below transmission centerline
Basic Model	793 mm (31.2 in)	377 kg (831 lbs)	335 mm (13.2 in)
With Retarder	793 mm (31.2 in)	411 kg (906 lbs)	335 mm (13.2 in)

*Approximate length from engine housing to output flange (depending on output flange type)

OUTPUT RETARDER PROVISION (OPTION)

Type	Capacity		Integral, hydraulic
	Torque	Power	
Level 3	2710 N•m (2000 lb-ft)	447 kW (600 hp)	
Level 2	2170 N•m (1600 lb-ft)	447 kW (600 hp)	
Level 1	1760 N•m (1300 lb-ft)	373 kW (500 hp)	

OIL SYSTEM

Oil type	Transynd™, DEXRON®-III
Capacity, excluding external circuits	38 litres (40 quarts)
Main circuit oil filter	Replaceable element, integral
Cooler circuit oil filter	Replaceable element, integral
Electronic oil level sensor (OLS)	Standard

SPEEDOMETER PROVISION

Description	Non-zero-crossing square wave
Location	8, 16 or 40 pulses per revolution of transmission output shaft Electronic output from TCM

TACHOGRAPH PROVISION

Tone wheel	4 or 6-tooth
Mounting	M18 x 1.5 metric thread
Location	Transmission rear cover or retarder housing

T525

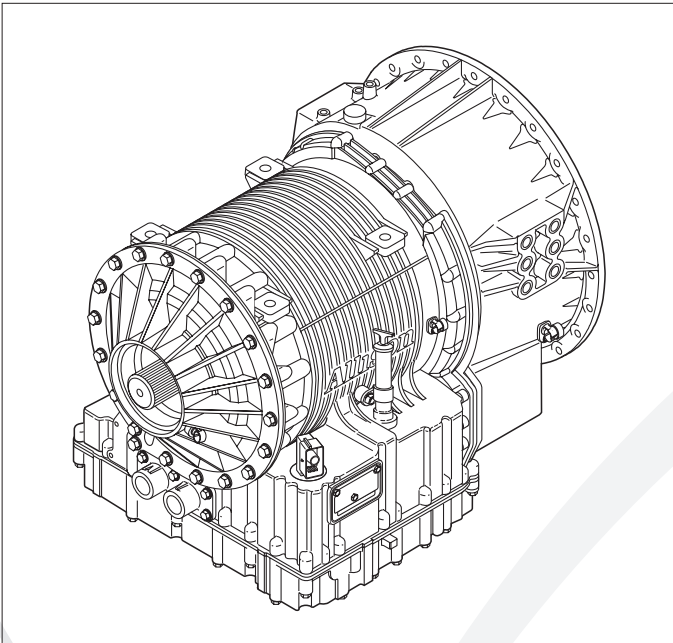

T525 (R)

